

WK8 mit Klemmnabe - axial steckbar

with clamping hub - axial pluggable

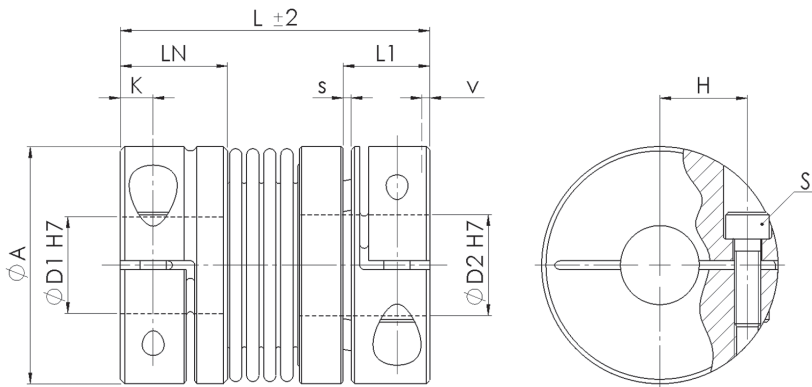

Material:
Balg - Edelstahl
Nabe - Aluminium
Temperaturbereich:
-30 °C bis +120 °C
Optional Passfedernut ØD1:
Nach DIN 6885

Material:
Bellow - stainless steel
Hub - aluminum
Temperature range:
-30 °C to +120 °C
Optional keyway ØD1:
Acc. to DIN 6885

WK8		Abmessungen Dimensions										ISO 4762	Technische Daten Technical Data		
Größe Size	TKN	L	ØA	ØD1	ØD2	LN	L1	s	v	K	H	S	TA	J	M
	[Nm]	[mm]											[Nm]	[kg cm ²]	[kg]
2	2	36	25	3 - 14	3 - 14	11	10	1	0,5	3,5	9	M3	2	0,02	0,03
		42												0,03	0,04
		46												0,04	0,04
4,5	4,5	48	32,5	6 - 18	5 - 14	13	13	1	0,5	4,5	11,5	M4	5	0,1	0,06
		56												0,1	0,07
10	10	54	40	6 - 25	5 - 18	14	13	1	1	4,7	15,5	M4	5	0,2	0,09
		64												0,3	0,12
18	18	56	45	8 - 25,4	10 - 21	20,5	13	1	0,5 - 1	5,75	17,5	M5	11	0,3	0,11
		62												0,4	0,12
		69												0,5	0,15
30	30	70	54	10 - 30	10 - 23	24,5	20	1,5	0,5 - 1	7,5	20	M6	19	1,2	0,27
		78												1,3	0,28
60	60	84	65	12 - 35	12 - 32	29	23	2	0,5 - 1,5	10	24	M8	42	3,3	0,5
		94												3,4	0,52
80	80	95	79	14 - 42	14 - 38	34	26	2	0,5 - 1,5	11,75	28	M10	83	7,8	0,79
		105												8,4	0,83
150	150	95	79	14 - 42	14 - 38	34	26	2	0,5 - 1,5	11,75	28	M10	83	7,8	0,79
		105												10,5	0,96
200	200	105	90	20 - 45	20 - 40	38	28	2	0,5 - 1,5	12,5	31,5	M12	145	14,7	1,16
		117												15,8	1,24
300	300	110	109	24 - 60	24 - 55	38	30	2	0,5 - 1,5	13	39	M12	145	32	1,8
		121												33	1,85
500	500	126	119	35 - 62	36 - 60	41,5	39	2	0,5 - 2	14,25	42	M14	255	50	2,25
		137												52	2,3

Massenträgheitsmoment und Masse sind mit dem größten Bohrungsdurchmesser gerechnet. Mass moment of inertia and mass are calculated with reference to the largest bore size. Laufend aktualisierte Daten finden Sie auf unserer Homepage. For continuously updated data please refer to our website.

Technische Daten

TKN - Drehmoment
TA - Anzugs-Drehmoment der Schraube
J - Massenträgheitsmoment
M - Masse

Technical Data

TKN - Torque
TA - Installation torque per screw
J - Mass moment of inertia
M - Mass

Bestellbeispiel / order example	WK8	30	78	14	20	SX
Modell / model						
Größe / size						
Länge / length						
Bohrung ØD1 H7 / bore ØD1 H7						
Bohrung ØD2 H7 / bore ØD2 H7						
Sonderoption / special option						

